

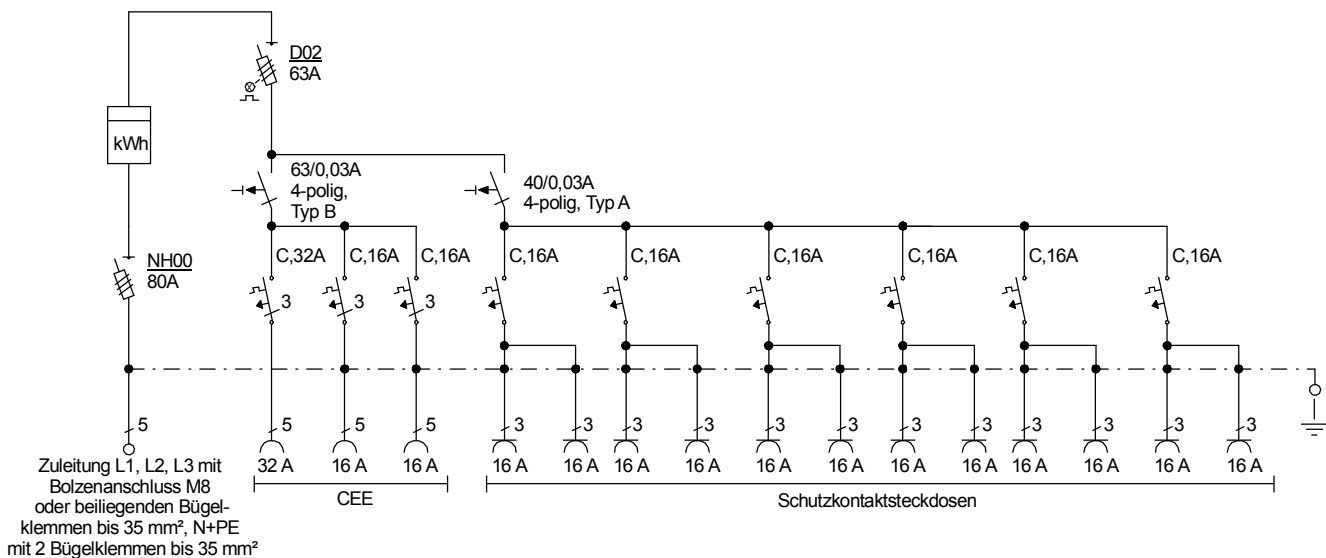

STEIDELE

Stromverteiler

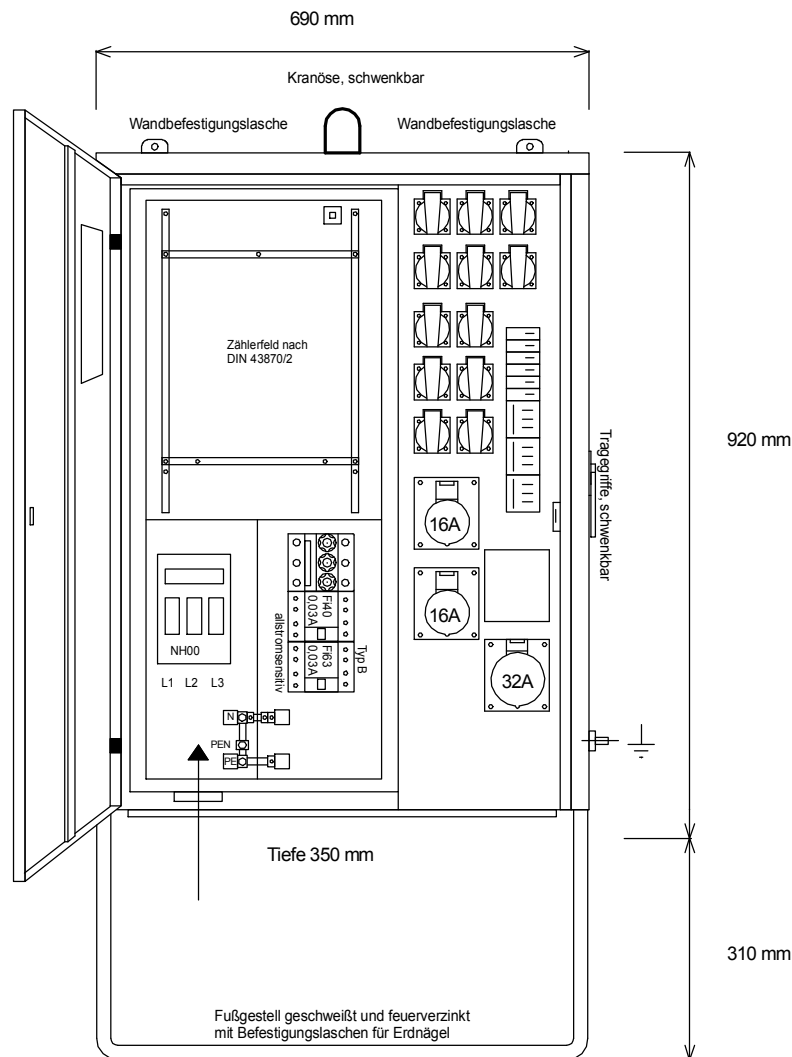
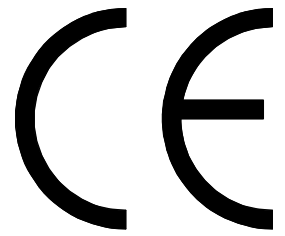

Entsprechend der neuen DIN VDE 0100-704/Okttober 2018

Typ: AV 63.2/21-12

Anschluss-Verteiler nach EN 61439-4

Leistung 44 kVA, Gewicht ca. 52 kg, Gehäuse 71

Best.Nr. 1580

gezeichnet am/von:

21.03.2017 / Uffinger